

**63 12 499 Headlight conversion, tourist solution, RHD/LHD traffic**

+ 63 12 999

**Preparatory work**

=> Installing and removing special tool, rear-wheel stand (motorcycles without main stand) (Item: 46 52 510, Billed as a separate item)

**Core activity**

(-) Affixing adhesive film for tourist solution, driving on right/driving on left conversion, to headlight

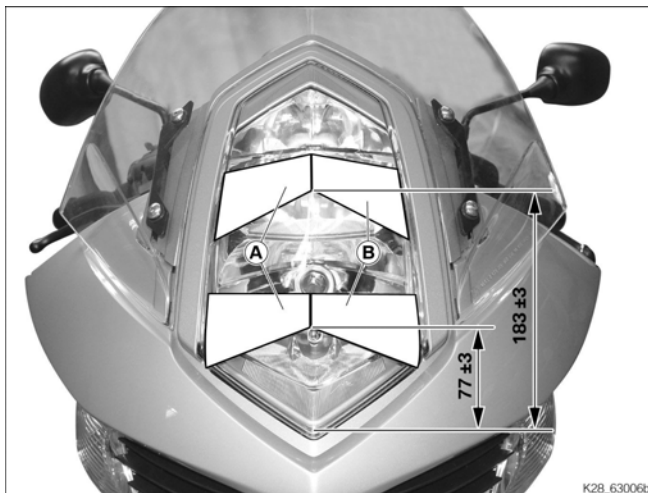
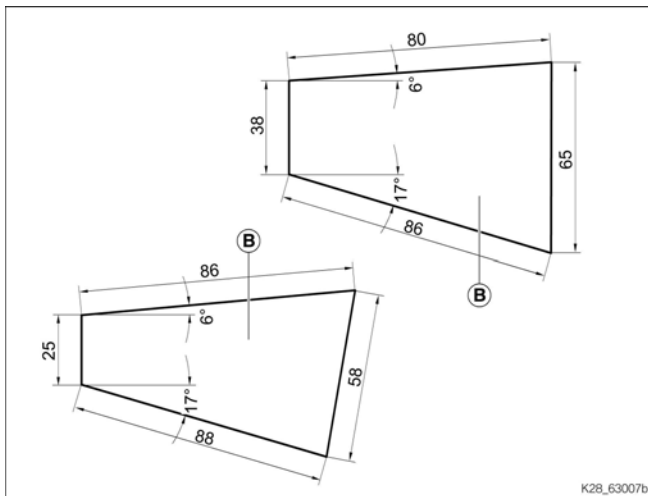
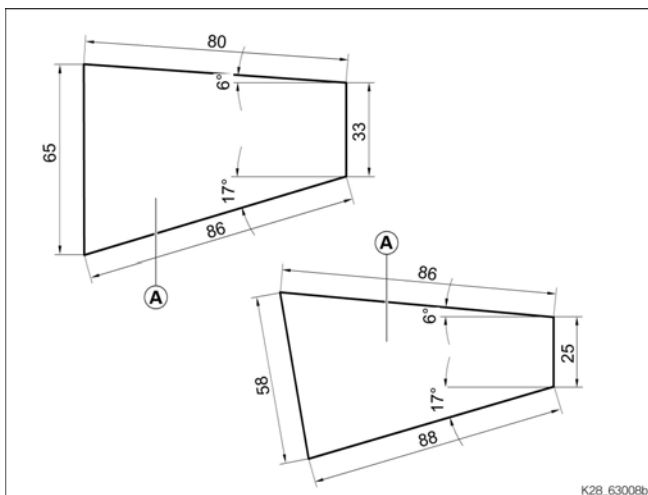

**Attention**

Commercially available adhesive tape will damage the plastic lens of the light.

Use only the special, black adhesive film for bodywork applications available from trade outlets.

- Cut out templates (A) to the correct size from the special adhesive film for **changing from driving on right to driving on left**.

- Cut out templates (B) to the correct size from the special adhesive film for **changing from driving on left to driving on right**.

- Apply cutouts of the special adhesive film to the headlight at the marked points (A) or (B), as applicable.

» The datum for the sizes is the bottom edge of the glass.

**(-) Removing adhesive film for tourist solution, driving on right/driving on left conversion, from headlight**



---

**Attention**

Damage to the plastic lens of the light.

Do not use solvents such as acetone, cellulose thinners, or similar products.

Do not use cleaning agents such as scouring powder or scouring solutions, and do not use scouring pads or similar products.

- 
- Remove the adhesive film from the headlight.
  - Use only a proprietary alcohol-based windscreen cleaning fluid to remove residues of the adhesive, if necessary.

**Finishing work**

Final check of work performed